

REVISIONS				
REV	ECN	DATE	DESCRIPTION	ISSUER
A	EC-00469	10/4/2016	RELEASE	RML

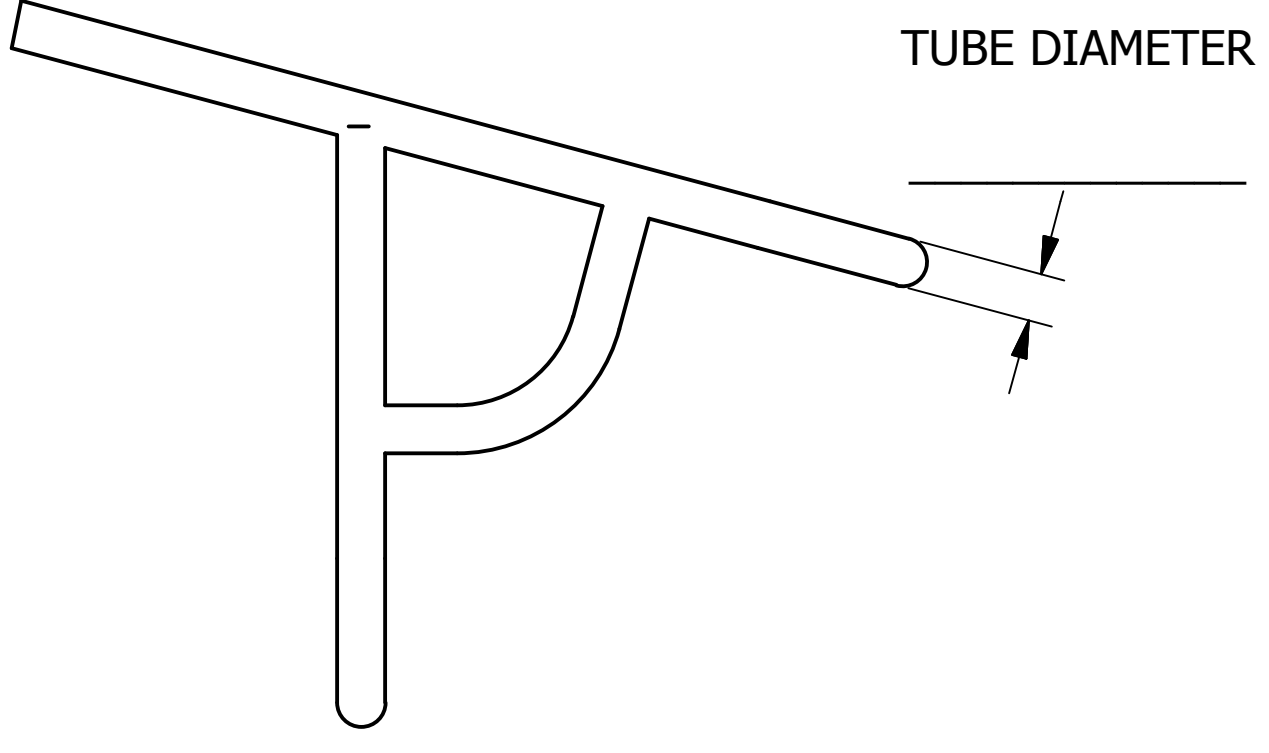
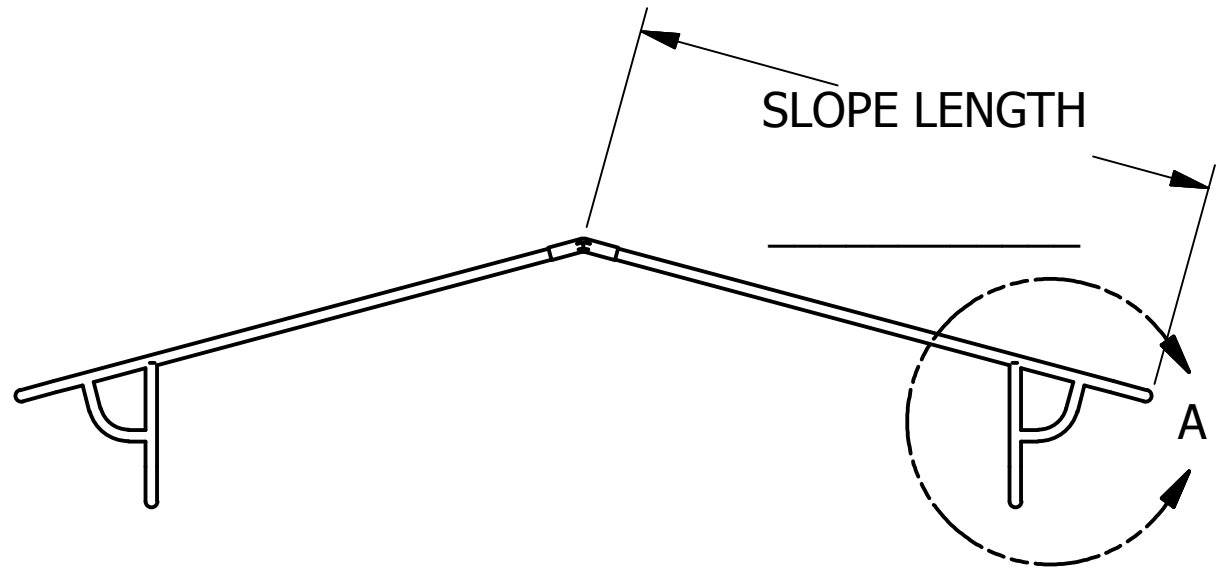

DETAIL A

ATTACHMENT METHOD(S)

---



---

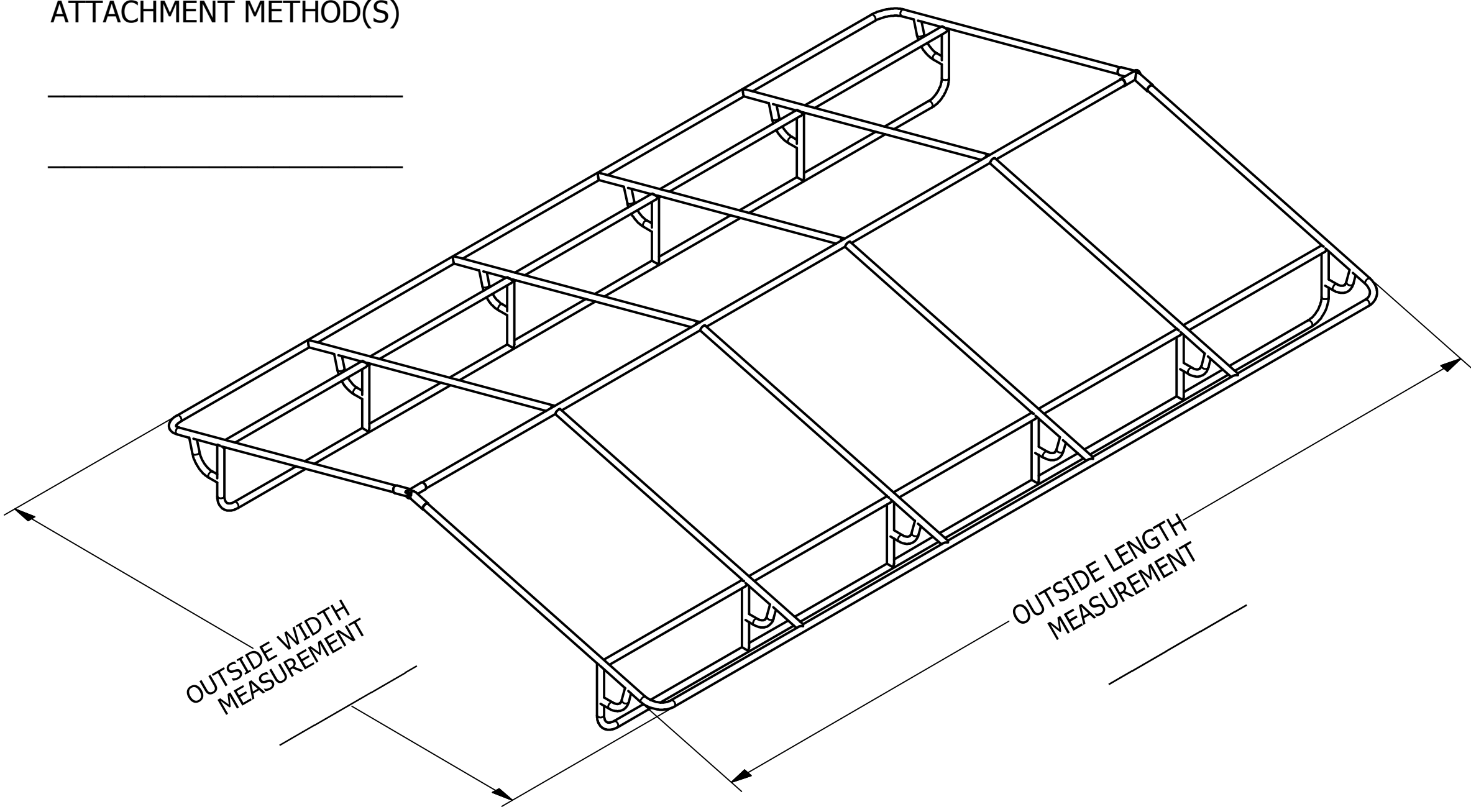

TOTAL NUMBER OF BOWS

---

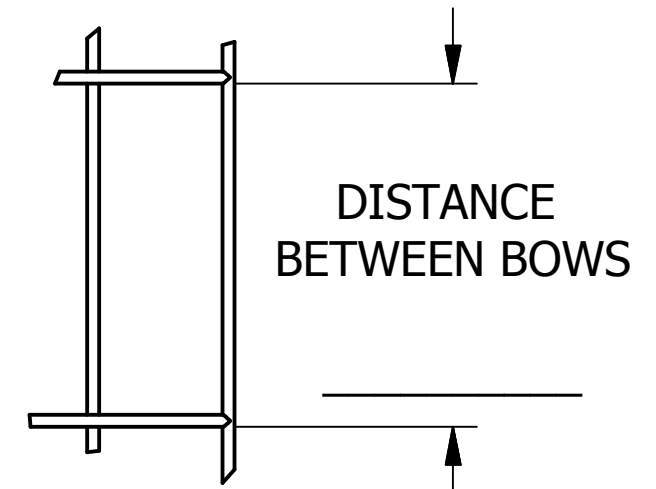
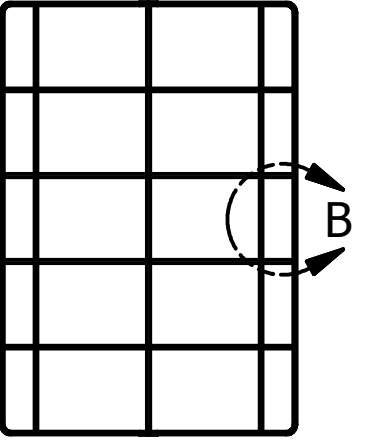

DETAIL B

SEND PICTURES AND IF NEEDED, ADD ANY ADDITIONAL FEATURES OR SKETCH THE VIEWS ON A SECOND PAGE.

TOLERANCES - UNLESS NOTED
DECIMAL ±
FRACTION ±
ANGLE ±
<b>NOTICE</b> THIS ILLUSTRATION IS THE PROPERTY OF RUSH-CO, AND MUST NOT BE USED IN ANY WAY DETRIMENTAL TO RUSH-CO'S INTERESTS.



1314 Walnut St. - Springfield, SD 57062 605-369-6000

TITLE: <b>STANDARD PEAK TOP FRAME DETAIL SHEET</b>			SIZE <b>C</b>
DRFT: <b>RML</b>	DATE <b>2/15/2016</b>	SCALE	SHEET <b>1</b>
ENGR: <b>CWG</b>	DATE <b>10/10/2016</b>		PART NO: <b>F-145</b>