

| REVISIONS | | | | |
|-----------|----------|-----------|-------------|--------|
| REV | ECN | DATE | DESCRIPTION | ISSUER |
| A | EC-00469 | 10/4/2016 | RELEASE | RML |

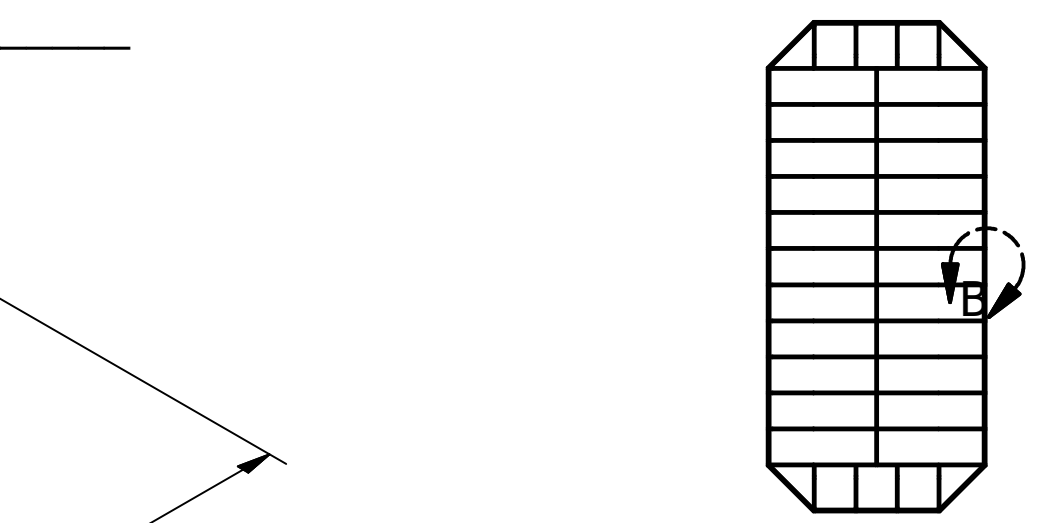

TOTAL # OF BOWS _____

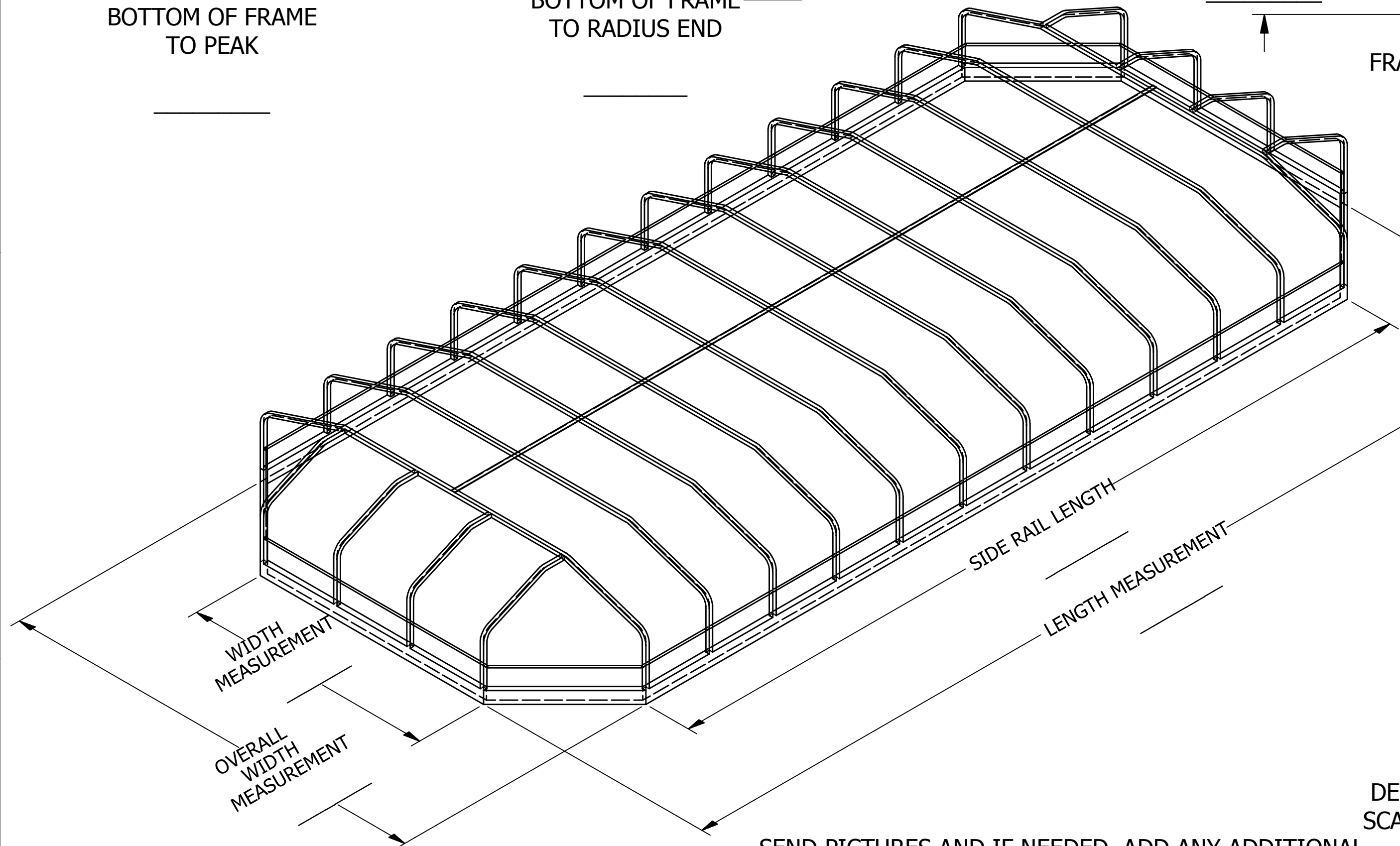
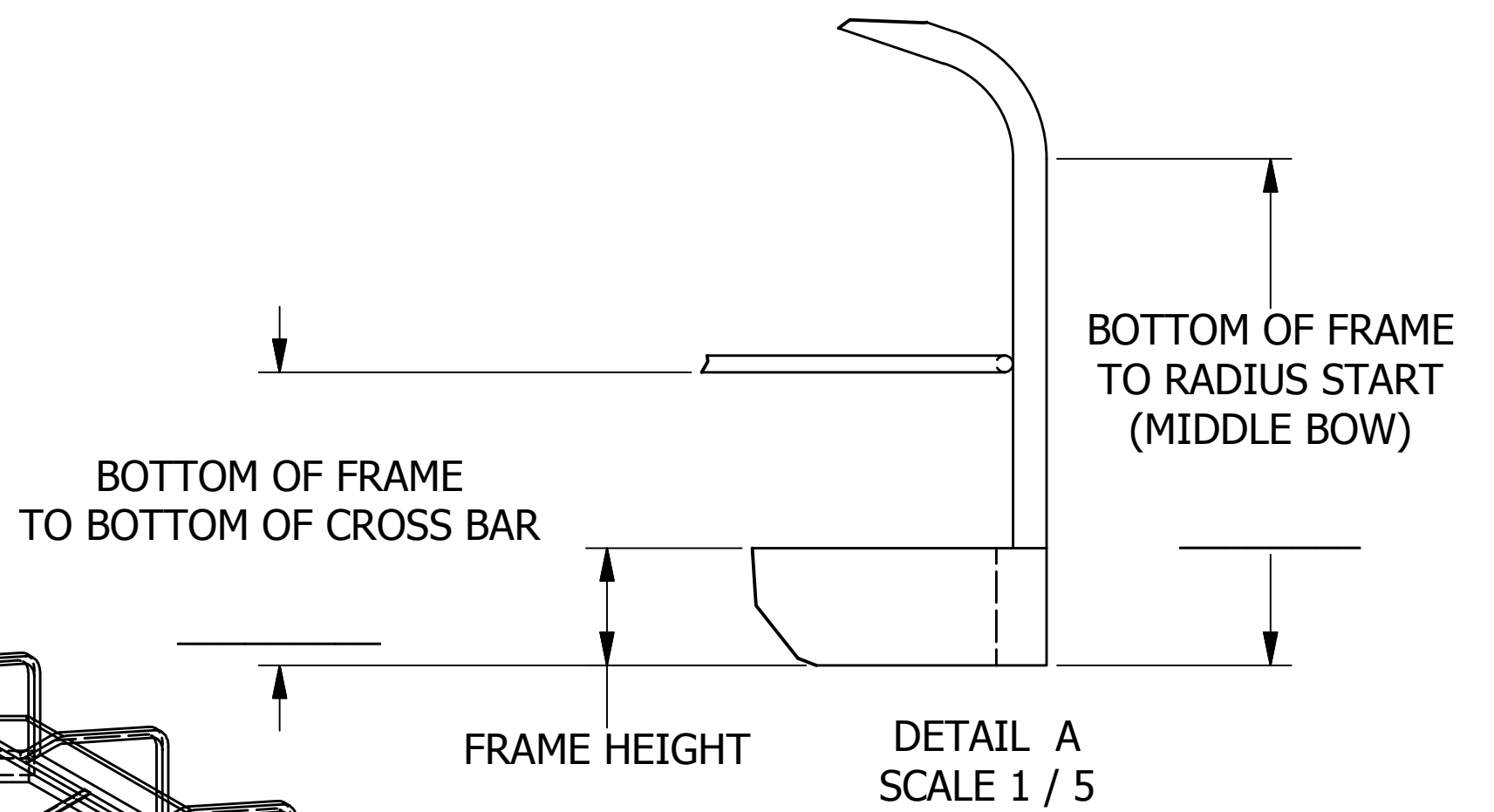
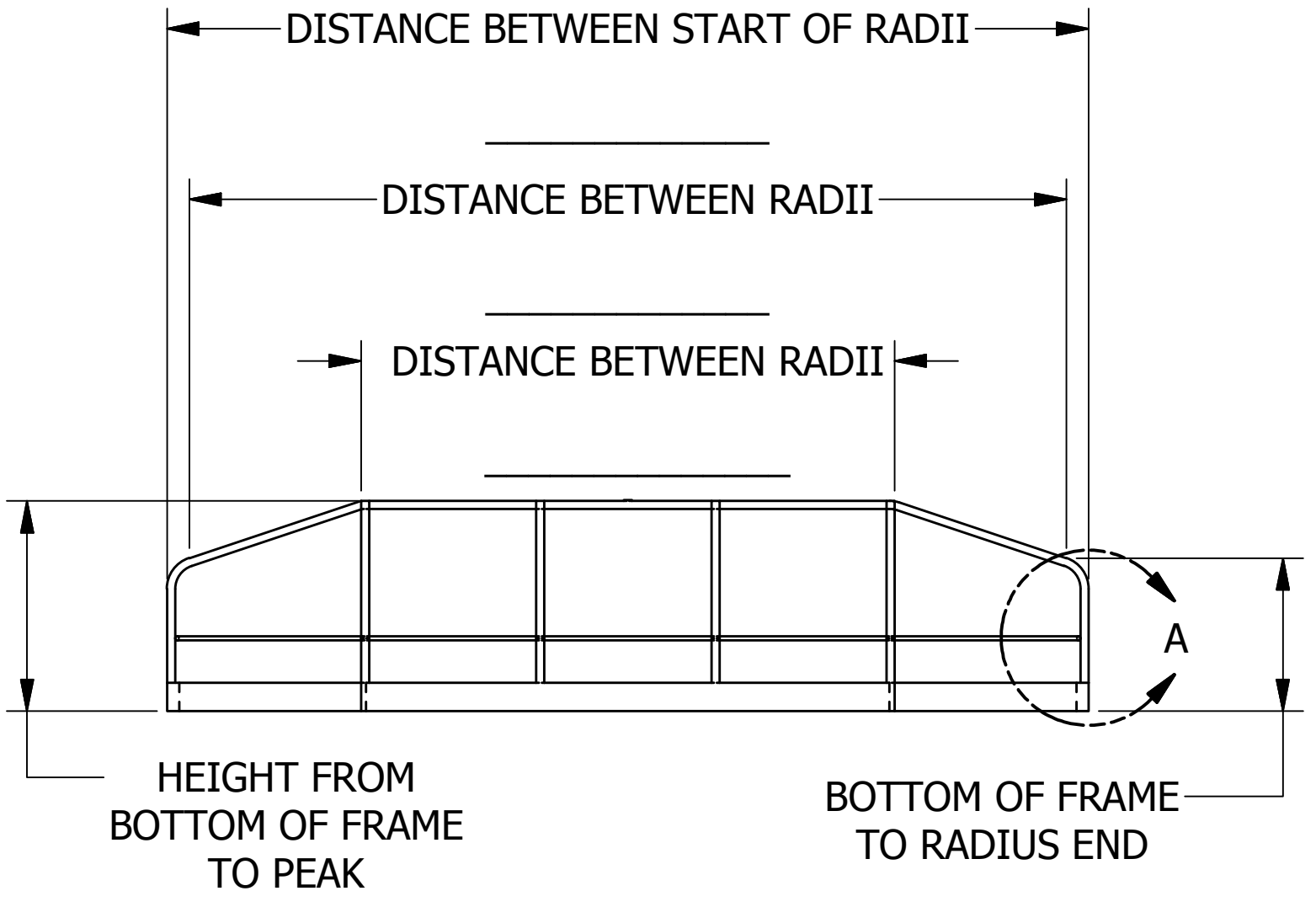
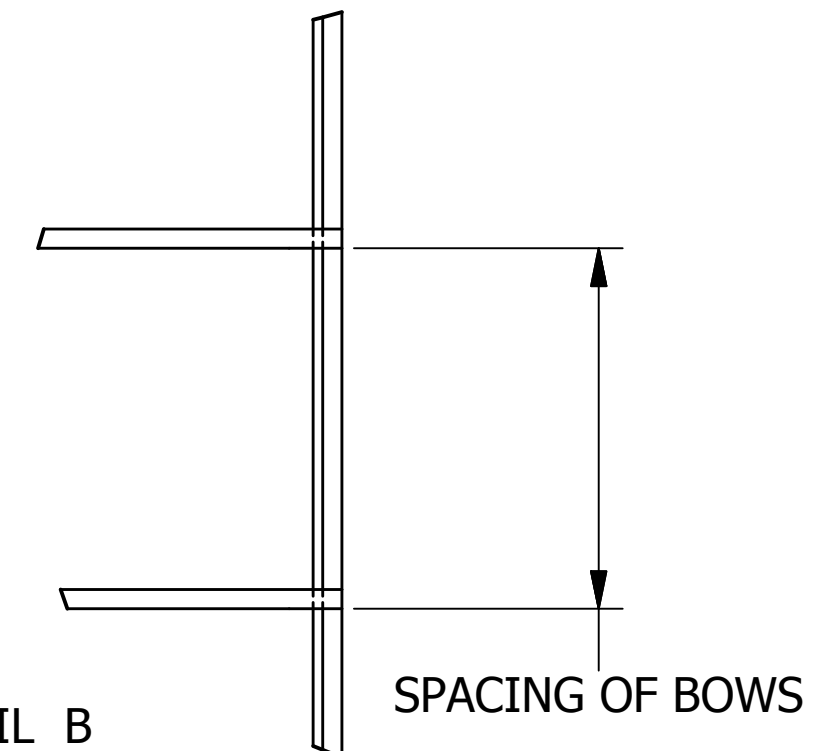

SEND PICTURES AND IF NEEDED, ADD ANY ADDITIONAL FEATURES OR SKETCH THE VIEWS ON A SECOND PAGE.

| | | | | | |
|--|--|--|--|--------|----------------------|
| TOLERANCES - UNLESS NOTED DECIMAL ± FRACTION ± ANGLE ± NOTICE THIS ILLUSTRATION IS THE PROPERTY OF RUSH-CO, AND MUST NOT BE USED IN ANY WAY DETRIMENTAL TO RUSH-CO'S INTERESTS. | | TITLE: RIDGELINE STYLE DETAIL SHEET | | | SIZE C |
| | | DRFT: RML ENGR: CWG | DATE: 1/3/2014 DATE: 10/10/2016 | SCALE: | SHEET: 1 1 |

